



Complying with the TRACED Act made simple

January 14, 2021

Speakers



Jim Dalton
TransNexus Inc.
CEO



Brian Ford
NTCA
Director of Industry Affairs



Alec Fenichel
TransNexus Inc.
Senior Software Architect

Agenda

- FCC Requirements
- ClearIP Robocall Mitigation Tools
- Non-IP Call Authentication Update
- Special Offer for NTCA Members
- Questions and Answers

FCC Requirements

- Pursuant to TRACED Act, the FCC in October 2020:
 - Required all voice service providers to implement caller-ID authentication (Stir/Shaken).
 - Granted “small carriers” (defined as those with fewer than 100k access lines) an extension until June 2023.
 - Exempted TDM providers (but must adopt alternatives if available).
 - **Any provider granted a delay or exemption must implement a “robocall mitigation program” to prevent unlawful calls from originating on their network.**

Mitigation Plans

- This plan must be focused on the **originating** side – providers must take steps to ensure that their networks are not used to originate illegal/unwanted/spoofed robocalls.
- Details provided by the FCC are limited. But,
 - ✓ Carriers must cooperate with law enforcement and industry “traceback” efforts that seek to determine the source of robocalls;
 - ✓ Plans must be designed to “significantly reduce” the origination of illegal calls;
 - ✓ Plans must be tailored to your individual company/network;
 - ✓ Plans must do more than engage vendor to monitor your network;
 - ✓ These are not a mere filing exercise – must be implemented and followed.

Mitigation Plans

- Reporting/certification requirements:

- ✓ Carriers must certify that they are authenticating all their traffic or have mitigation plans in place (approx. due date of July 1, 2021);
- ✓ The failure to file this certification (along with the mitigation plan) triggers a **requirement** that all intermediate providers stop accepting your traffic.

- Consequences:

- Those carriers found to have deficient plans/do not follow the plans face FCC enforcement:
 - Loss of extension/exemption;
 - FCC adopting much more stringent requirements for individual companies;
 - Certification pulled from the database – and traffic no longer accepted by upstream providers.

ClearIP Robocall Mitigation Tools

- Calling number controls
- Real time reports for problematic calling numbers:
 - Invalid
 - Do Not Originate (DNO)
 - Bad reputation (marked as spam in call analytics)

ClearIP Robocall Mitigation Benefits

- Full compliance with FCC requirements
 - Ensure only ~~valid~~ pristine calling numbers egress your network
- Identify good subscriber calling numbers that are labeled as spam
 - Restore good subscriber calling number's reputation
- Real time analytics and control
- Simple

Simple Network Integration

Configure ClearIP as the first
outbound trunk group for every call

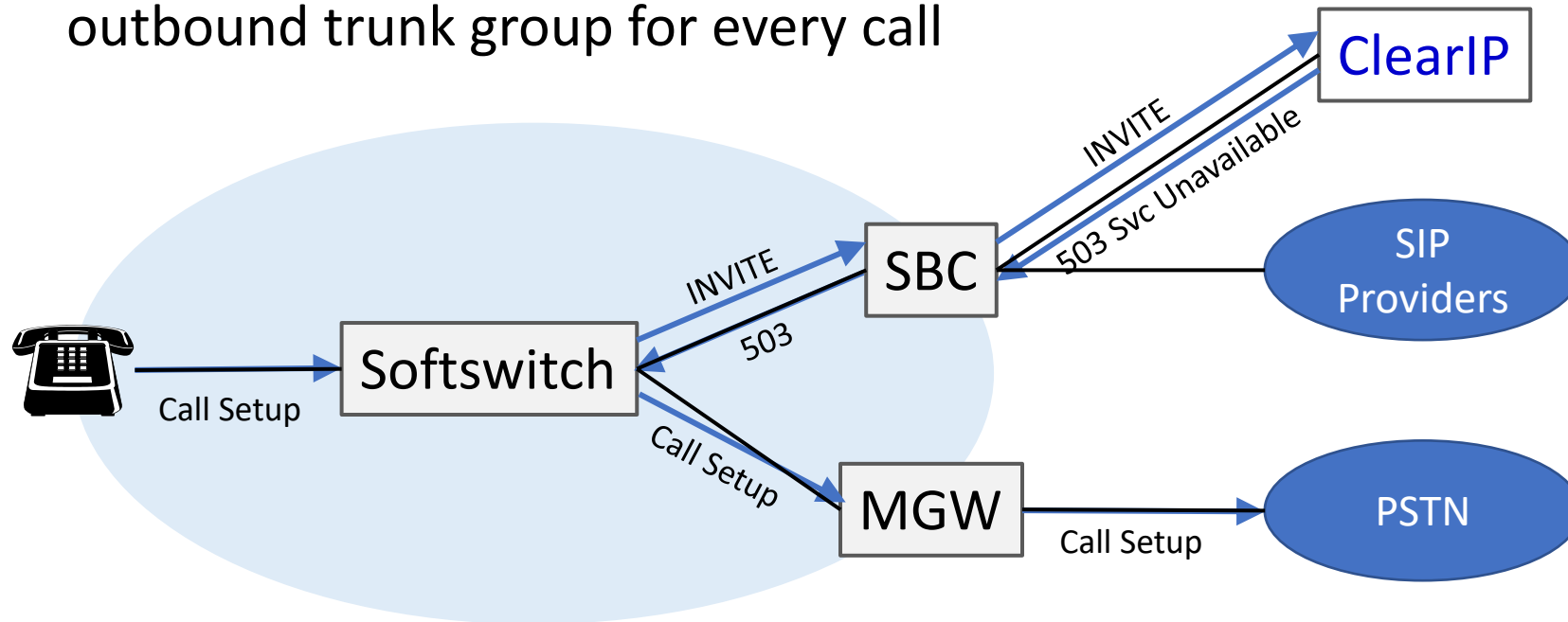

Route advance to next
trunk group to complete call

Integration for TDM switches

Configure ClearIP as the first
outbound trunk group for every call

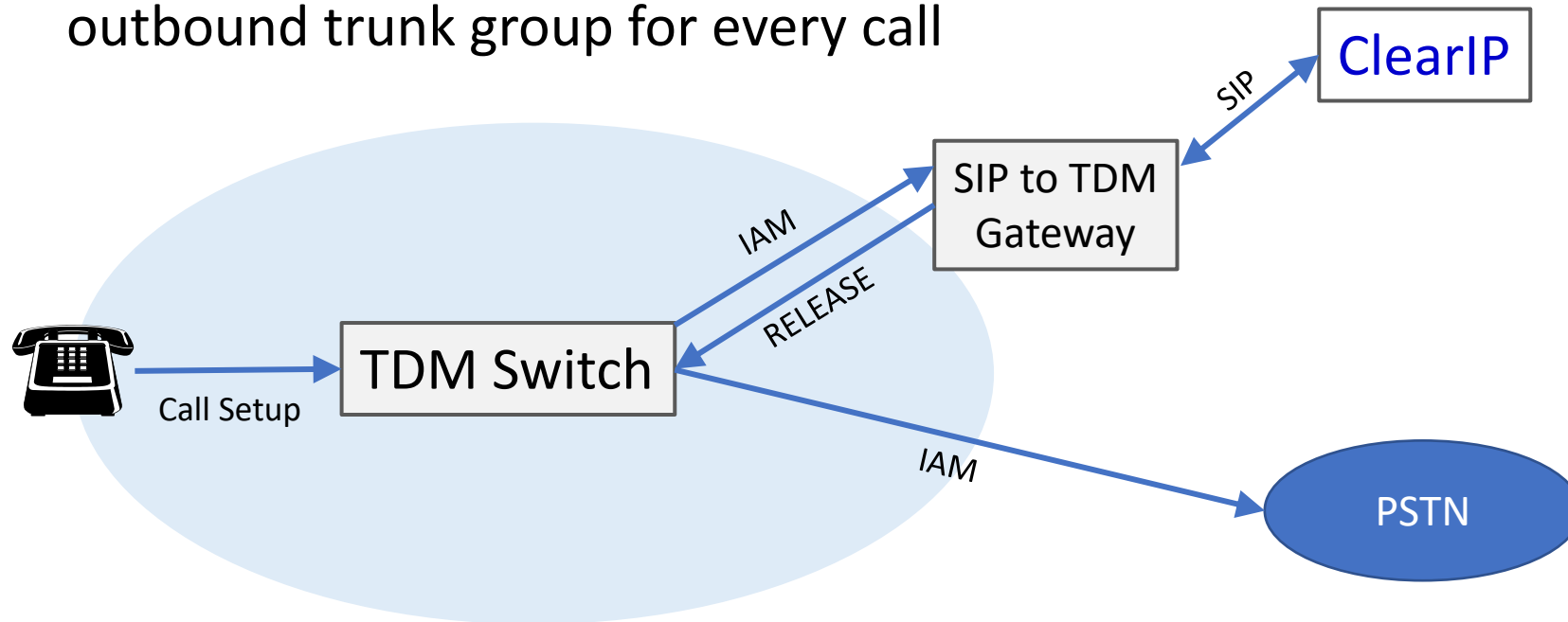

Route advance to next
trunk group to complete call

Demo of Robocall Mitigation Tools

Non-IP Call Authentication Update

- ATIS PTSC Non-IP Call Authentication Task Force created in May 2020
- *Out-of-Band Token Transmission for TDM Networks*
 - Extends SHAKEN to TDM networks
 - Co-authored by
 - NetNumber
 - NeuStar
 - TransNexus
 - Approval expected in March 2021

Non-IP Call Authentication – How it Works

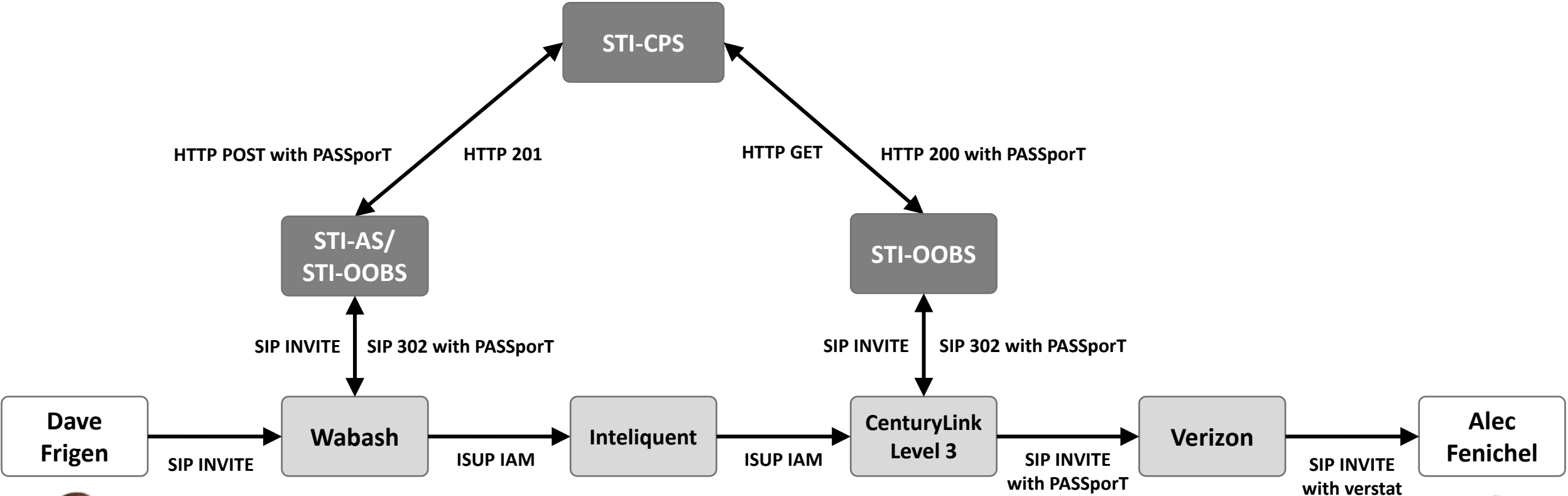

Demo of SHAKEN Features

Special Offer for NTCA Members

- ClearIP Robocall Mitigation Tools
 - Everything you need for FCC compliance
 - Identify when your subscribers calling numbers are marked as spam
 - No on-premises equipment or up-front cost
 - Billed monthly based upon usage with no contract or commitment
 - Additional features: inbound robocall prevention, TDoS prevention, toll fraud prevention, least cost routing, SHAKEN and CNAM
- \$500 ClearIP service credit for NTCA members who sign-up by March 31, 2021
- NTCA members who register with the STI-PA by March 31, 2021
 - \$1,000 ClearIP service credit
 - Free, unlimited Non-IP call authentication for all of 2021
- For TDM switches, TelcoBridges offers free installation of TMG 800 gateway
 - TMG 800 SIP to TDM gateway must be purchased by March 31, 2021

Questions & Answers

How to get started?

- Contact Jim.Dalton@TransNexus.com for a demo and more information